

INSTALLATION MANUAL

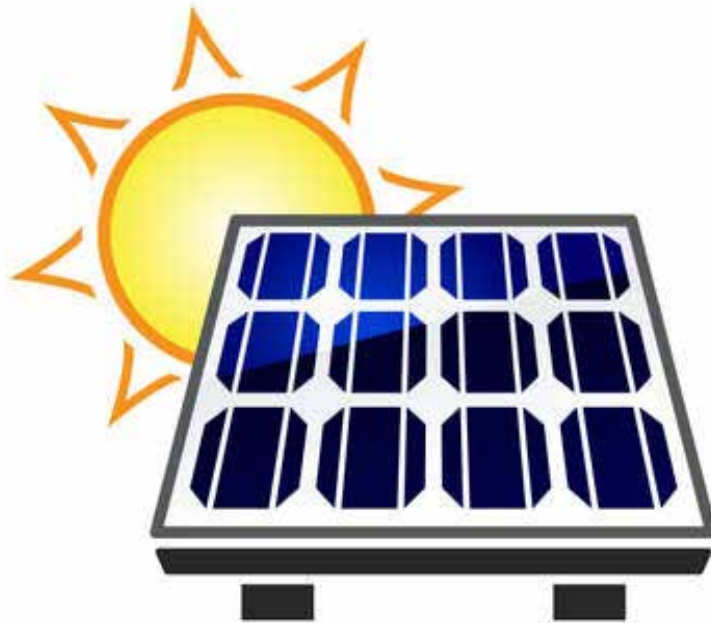



KIT **Frog[®]+** FORCED
by Sunerg Solar

KIT **Frog[®]+** WITHOUT BOILER
by Sunerg Solar

KIT **Frog[®]+** NATURAL
by Sunerg Solar



Meaning of symbols

	Failure to comply with these instructions carries a risk of death by voltage.
	Failure to comply with these instructions may cause serious health damage, e.g. burns or serious injury.
	Failure to comply with these instructions may cause serious damage to the control unit, to the plant or environment.
	Particularly important information for the operation and optimal use of the plant.

General Instructions

This technical documentation and assembly instructions, contain basic and important information regarding safety, installation, setting, maintenance and optimal use. Therefore these instructions must be fully read and understood by the specialist installer/technician and the system user before installation, start-up and operation of the unit. Applicable safety regulations, reference laws, applicable DINEN standards and installation and operating instructions of the components that are part of the system must be observed. Assembly, electrical connection, start-up and maintenance of the equipment must be carried out only by qualified technicians.

Always keep this documentation close to the product.

Modifications on the equipment

- Modifications or additions are not permitted without the written consent of the manufacturer.
- It is also prohibited to install add-ons which have not been tested by the producer.
- The electrical resistance has been specially designed for this purpose and cannot be replaced by other electrical resistances.
- Any component or accessory which is not in perfect condition must be immediately replaced with an original product.
- The photovoltaic modules used cannot be increased or decreased as quantity and can not be replaced unless after the manufacturer authorization and in any case with modules of equal characteristics.

	Modifications to the equipment may compromise the safety and operation of the entire system
---	---

Warranty and Liability

The whole system is covered by warranty as described below:

- 2 years for electrical parts
- 5 years for the boiler
- 25/30 Years for photovoltaic modules.

The warranty and liability does not, however, include any damage to persons or material attributable to one or more of the following causes :

- * Failure to observe these installation and operation instructions
- * Incorrect installation, start-up, maintenance or use
- * Repairs carried out improperly
- * Unauthorised structural changes to the system
- * Installation of add-ons not tested by the manufacturer
- * Any damage resulting from prolonged use, despite there is an objective defect
- * Failure to use original components and accessories
- * Use of the system for purposes other than that for which it was manufactured
- * Operation above or below the limit values listed in the technical specifications
- * The system is not covered by warranty for problems caused by limestone
- * Force majeure causes

Electrical Resistance Installation



Before proceeding to the installation and connection of the electrical resistance read carefully and make sure that you have understood the following instructions.

Boiler Installation (only for Frog+ Forced and Frog+ Natural)



- Place and fasten the boiler firmly on the wall by means of suitable brackets.
- Inside the boiler must be inserted the photovoltaic electrical resistance (this resistance must not be connected to the grid of the distributor) the same is already equipped with thermostat 90°C.
- To connect the cables of the resistance to the line coming from the photovoltaic through suitable junction box, it is advisable to provide between the photovoltaic and the resistance a suitable magnetothermic protection or fuses.
- The connection to the grounding system is mandatory.
- Connect on the appropriate connections, the cold water inlet and hot water outlet.
- The installation of a thermostatic mixer is mandatory if there are high temperatures.

Photovoltaic Modules Installation



-The amount of photovoltaic modules ranges from 2 to 4 , depending on the model of the system

Componenti Components	KITFROG_F150/2	KITFROG_F200/3	KITFROG_F300/3	KITFROG_F300/4
Moduli Fotovoltaici (n.) Photovoltaic Modules (n.)	400/520 Wp (2) <small>(COLLEGAMENTO MODULI IN PARALLELO)</small>	400/520 Wp (3) <small>(COLLEGAMENTO MODULI IN PARALLELO)</small>	400/520 Wp (3) <small>(COLLEGAMENTO MODULI IN PARALLELO)</small>	400/520 Wp (4) <small>(PARALLELO 2+2)</small>
Resistenza elettrica intelligente 1* Intelligent electric heating element 1*	RCF2	RCF3	RCF3	RCF4
*SMART CONTROL APP WIFI Smart controller per temperatura bollitore con APP da cellulare Smart controller for boiler temperature with mobile phone APP	FROG_APP+	FROG_APP+	FROG_APP+	FROG_APP+
Bollitore doppio serpentino HB HBW Tank with 2 coils	HB150	HB200	HB300	HB300
Telaio per tetto inclinato (n.) Frame for slanted roof (n.)	KIT_TEL2F	KIT_TEL3F	KIT_TEL3F	KIT_TEL2F (2)
Pallettizzazione kit packaging	STANDARD PK	STANDARD PK	STANDARD PK	STANDARD PK

- The modules must be fixed by qualified personnel, in compliance with the installation rules for photovoltaic systems.
- Module structure must be grounded with suitable fasteners, not supplied as standard

Electrical connections and warnings



- Electrical connections may only be made by a qualified technician, in compliance with the relevant regulations.
- The modules must be connected in series. Use appropriate connectors (PV4 or MC4) for the connections.
- Connect the panels to the heating element using solar cable of the appropriate cross-section, taking into account the distance between the photovoltaic modules and the boiler.
- Install suitable circuit breakers or fuses between the modules and the boiler.**
- Panels exposed to the sun are always live, so take extreme care when making connections.**

Electrical Connections

Electrical connections with connectors supplied as standard and electrical cable of adequate cross-section, taking into account the distance between the modules and the boiler. The parallel connection of the modules ensures compliance with the CEI64-8 standard specific for this type of installation.

Hydraulic Connections

For hydraulic connections refer to the specific boiler manual.

Example of electrical installation with WI-FI control unit

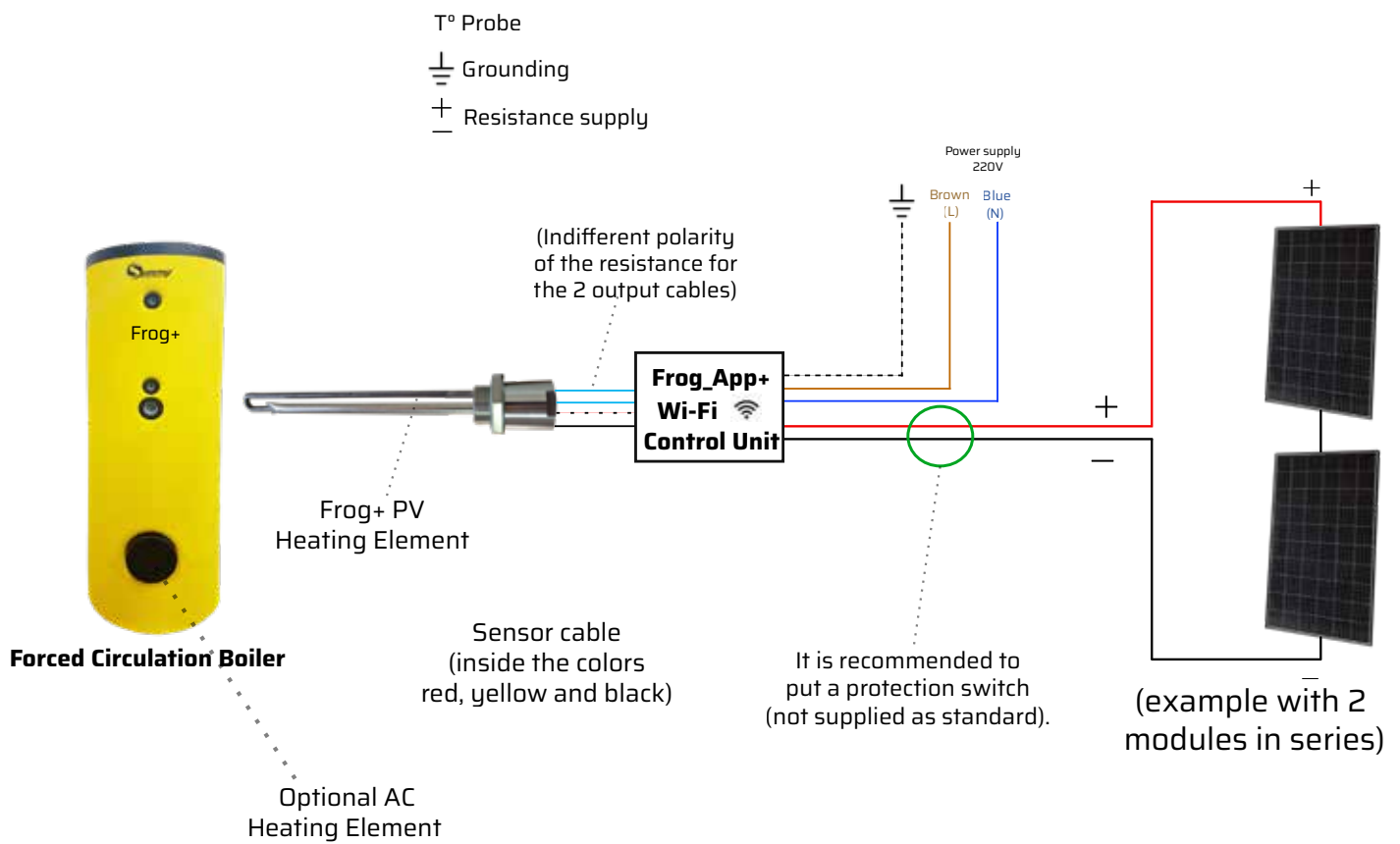

Kit Frog+ natural

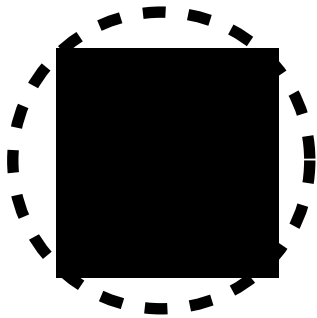

B. Safety valve

A. Pit



Insert the temperature sensor into the sump (point A)

Connect the two cables in parallel to the heating element.

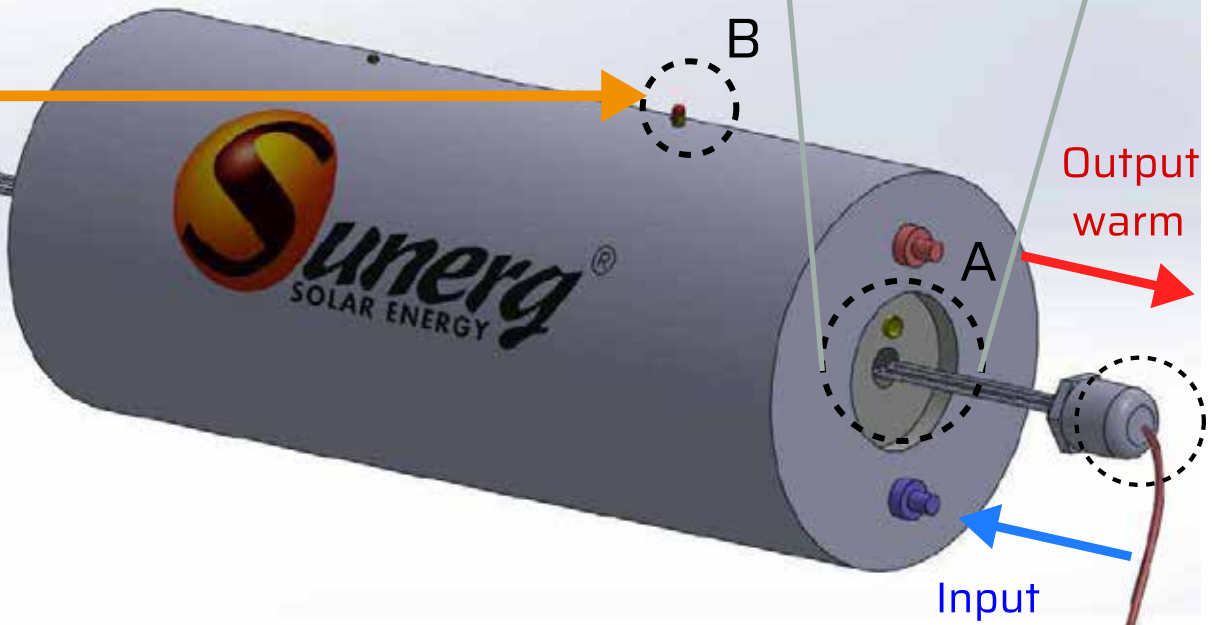
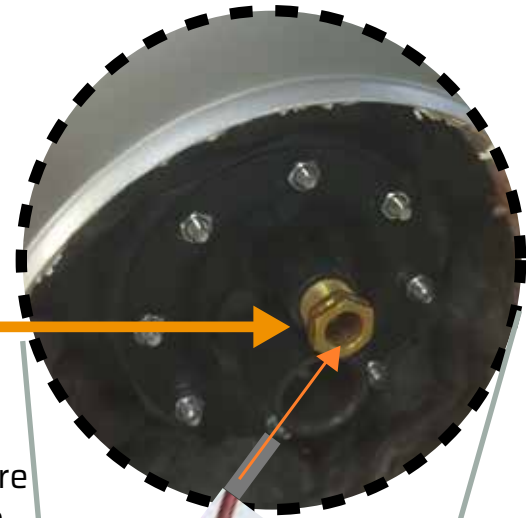

D. 1500W 220V resistance included in the boiler (optional connection)

C. Resistance Frog+ PV

Frog+ natural electrical installation

Example of electrical installation with Wi-Fi control unit

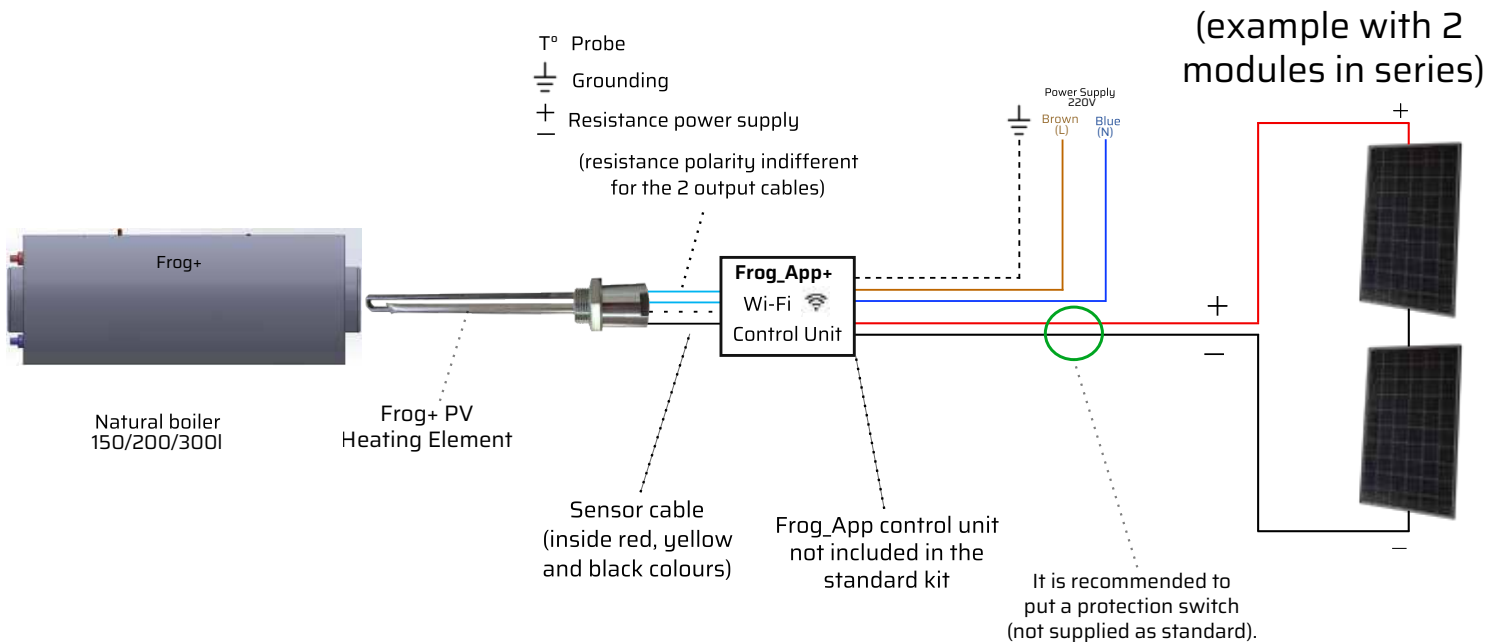

Example of electrical installation without Wi-Fi control unit

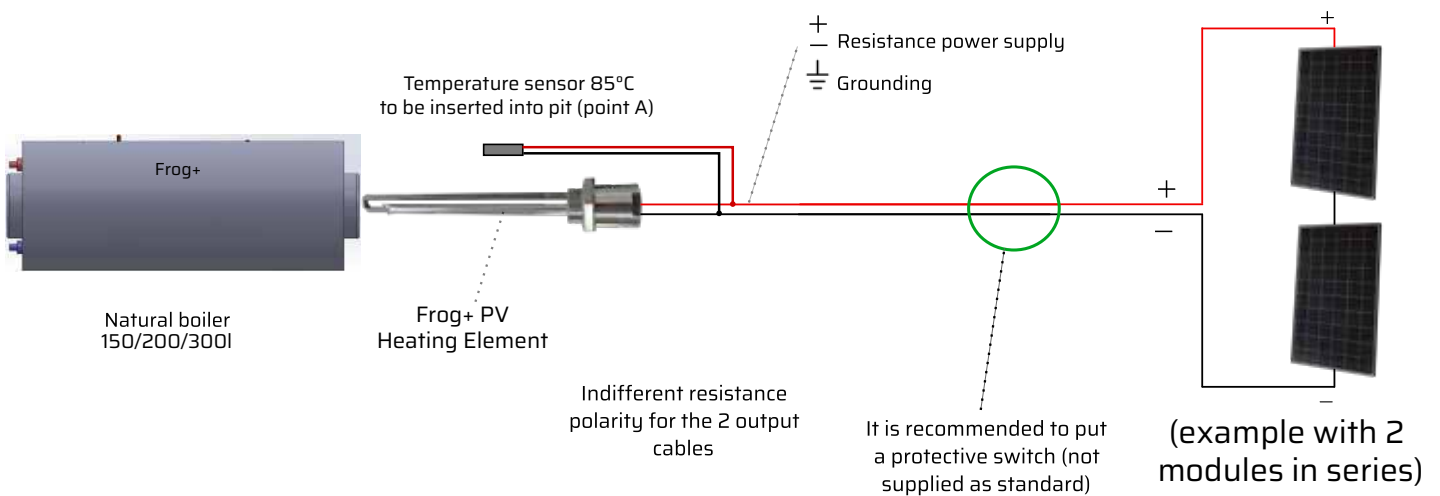

With this solution, when exceeding 60V DC, in compliance with CEI 64/8, a device for protection against indirect contact (type B residual current devices [RCD]) must be provided, which is not supplied as standard

For the Natural Frog+ Kits, the Frog_App control unit is optional, not included in the kit.

Frog_App+

Single-line electrical diagram

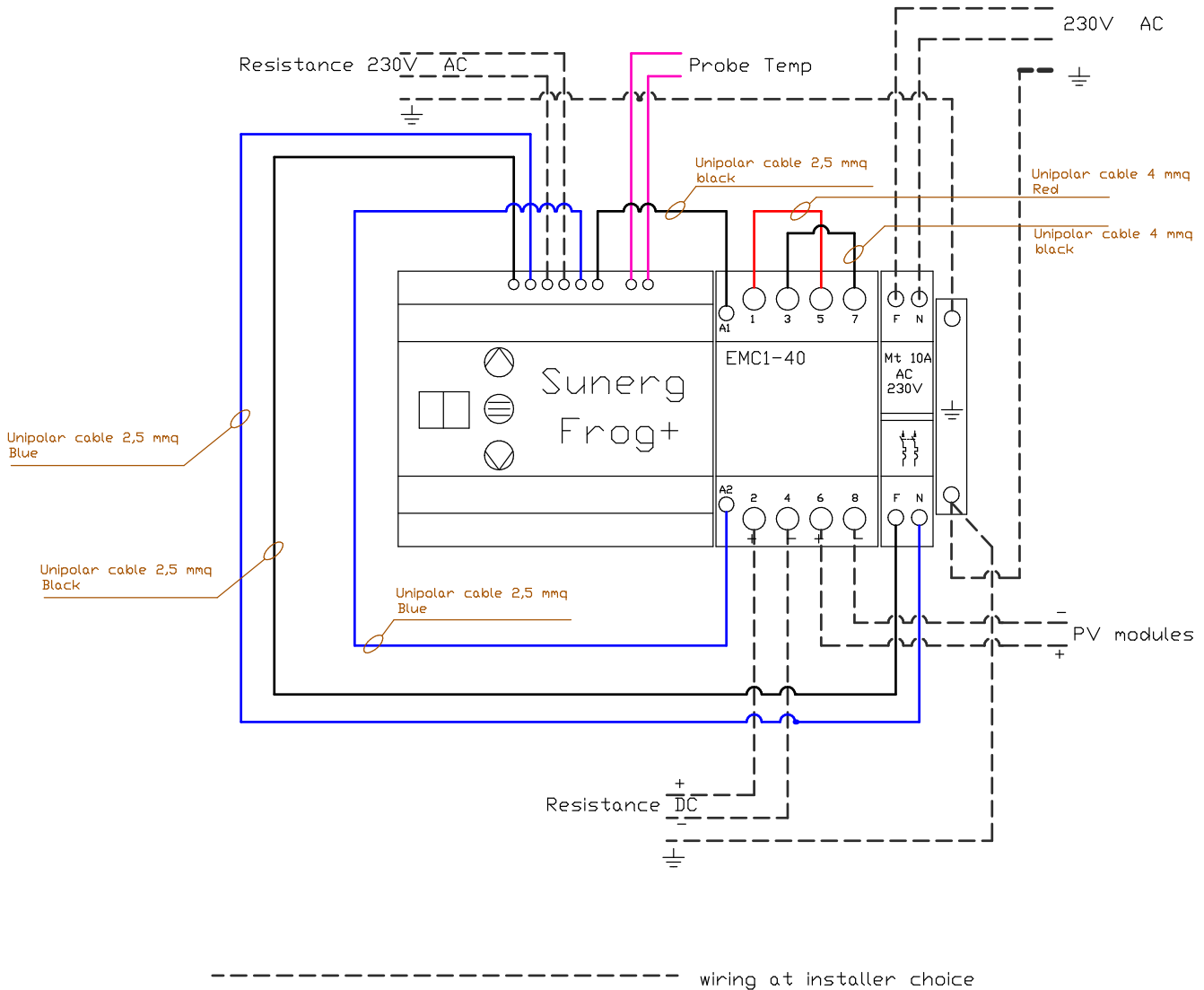

Note: the control unit on the AC line is equipped with a 2x10A magneto-thermal switch, this is for the protection of the auxiliary circuit and the AC electric resistance. It is advisable to install appropriate magneto-thermal protection and surge protector on the DC line. Grounding is mandatory.

Complete photo frame (interior and exterior)

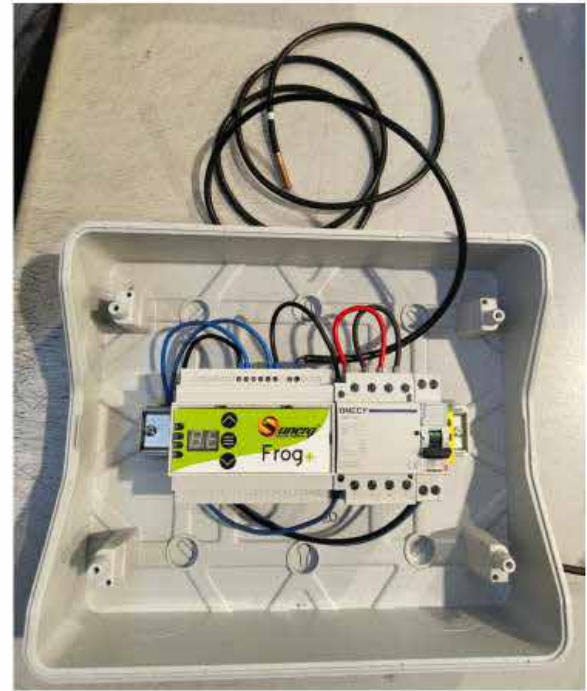

Inside the enclosure, there are 6 PG9 cable glands to be installed by the installer for cable entry and exit.

Connections

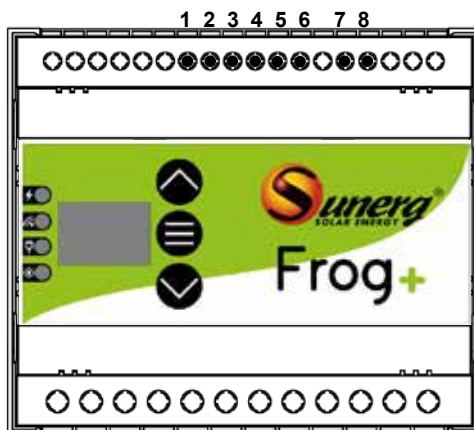

Terminal block	Description
1,2	Neutral input and power line 230Vac
3,4	Output 230Vac 16A for integrated resistance
5,6	Input 230Vac contactor command
7,8	Probe storage temperature

Tabella 1: Descrizione Morsettiere

Technical data

Power and consumption	
Network voltage	195-240VAC @ 50-60Hz
Nominal consumption	tbdW (@230V 50Hz 25°C, with all outputs ON, no loads connected)
Protection	The kit includes a 2x10A thermal magnetic circuit breaker for the protection of the auxiliary circuit and a 230V AC supplementary resistor.
Outputs	
Output 3,4	Supplementary power supply 230 V AC
Output 5,6	Coil power supply contactor DC resistance
Inputs	
Input 7,8	Type: NTC temperature probe ($\beta=3435$, 10k @25°C) or PT1000 Measure temperature field NTC: from 0°C to 99°C; Cable length: < 10m (minimum section 0.25mm ²);
Dimensions	
External dimensions	90x105x65 mm
Condizioni di installazione	
Operating temperature	0°C + tbd °C
Humidity	95% max 40°C
Weight	tbd g
Protection rate	IP20
Device classification	
Action type	tbd
Category	tbd
Nominal pulse tension	2500 V
EMC test voltage	AC: 230V, 50Hz

LED status indicators

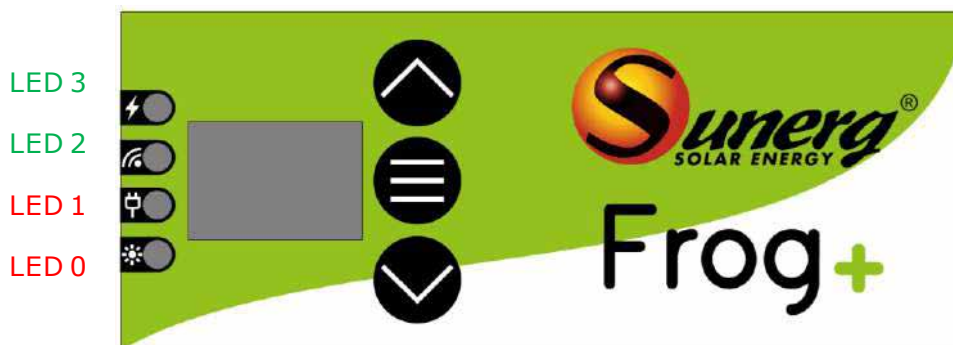

Fig. 1 CAM80430_02

LED	Color	Meaning	Description
LED 3	Green	Presence of 230Vac tension on the control unit	power is on if the voltage 230Vac is present on the CAM80430_02 control unit;
LED 2	Green	WiFi module status	<ul style="list-style-type: none"> It flashes 1s On every 10s: WiFi module in Low Power mode; It flashes at a frequency of 5Hz if the WiFi module is in SMART CONFIG state; Brief pulse On every second: WiFi configured but not connected; Brief pulse Off every second: WiFi connected, but not reaching the CLOUD; Always On: the WiFi module is connected to the CLOUD; Flashes slowly, 1 second On and 1 second Off: module in an undefined state.
LED 1	Red	Heating AC output status	The LED is on if the relay controlling the AC heater is active. It flashes at a frequency of 5Hz during the adjustment of the AC setpoint.
LED 0	Red	State of output supplementary heating DC	The LED is on if the control relay of the DC heater is active. It flashes at a frequency of 5Hz during the modification of the DC setpoint

Tab 2: LED indications

Power On/Off

If the system is in the Off state, then the 7-segment display shows a double horizontal line [- -]; If, on the other hand, the system is in the On state, then the display indicates, if there are no anomalies, the temperature read by the sensor. To toggle between On/Off states, press and hold the central button for at least one second.

Temperature probe

The temperature probe must be connected to the appropriate terminal block. The cable must not exceed a length of 10 meters. The use of a ST07 probe is foreseen. The temperature value measured by the probe is displayed on the numerical display with a range of values between 00°C and 99°C. If the corresponding temperature drops below -5°C, the probe is considered interrupted, and instead of the temperature value, an error message appears. If the temperature measurement detects a value above 105°C, then an error report will appear on the numerical display. In case of an anomaly detected in the temperature probe, the outputs are turned OFF.

ERROR CODES

Error report on the numeric display	Description
E1	Temperature probe in short circuit
E2	Temperature probe in open circuit

Tab 3: error codes

AC Setpoint Adjustment

With the control unit in the On state, press and release the upper button: The setpoint value for AC control starts to blink on the numeric display and LED1, corresponding to the AC output, blinks at a frequency of 5Hz. During the blinking of the temperature setpoint, adjust the value using the upper and lower buttons. The buttons must be pressed and briefly released to change by one unit or continuously pressed for continuous adjustment from the value. The blinking of the setpoint lasts for 10 seconds from the last change. To confirm the value before the blinking ends, press and release the central button. At the end of the adjustment, a beep is emitted, and the value is stored non-volatilely.

DC Setpoint Adjustment

With the control unit in the On state, press and release the lower button. The setpoint value related to DC control begins to flash on the display and LED0 flashes at a frequency of 5Hz. The adjustment occurs in the same way as described in the previous paragraph.

Setpoint	Default value °C	Lower limit °C	Higher limit °C
AC	60	30	75
DC	80	10	90

Tab4: values camp temperature setpoint

Device Pairing Smartphone

Access Google Playstore. Search for the app "Smart Life - Smart Living" by "Volcano Technology Limited". Install the app or, if already installed on the smartphone, check and update to the latest version.

Connect the smartphone to the same WiFi network to which you want to connect the CAM80429_01 control unit. You need to know the SSID and password of the WiFi network.

In the settings, make sure the WiFi network is geolocatable. With the smartphone, ensure you have a good signal level of the network near the control unit.

With the smartphone, check to have a good signal level of the network near the control unit. Also enable the Bluetooth connectivity of the smartphone.

Power on the CAM80429_01 control unit; if it is in the OFF state, the display shows two horizontal lines [- -]: in this case, switch it to the ON state by pressing the center button for about a second. When the control unit switches to the ON state, it will display the temperature read by the probe. Check the status of the green LED2: If it is blinking quickly (at a frequency of 5Hz), then the WiFi module in the control unit is in SMART CONFIG state, therefore ready to be detected and connected to a WiFi network.

Note	<p>If LED2 does not blink quickly, then it is possible to return the WiFi module, if necessary, to SMART CONFIG mode by following the procedure below:</p> <ul style="list-style-type: none"> • With the control unit in the ON state, press and release only the central button: the display shows the prompt [C _] to enter a command; • With the upper and lower buttons, adjust the flashing horizontal dash on the right side of the display to change it to the value equal to 0, so that the display shows the text [C 0]; • At this point, press and hold the central button for about 1 second; (be careful to only press the central button without touching the adjacent ones). • Wait about 10 seconds; <p>At this point, the WiFi module should be in SMART CONFIG mode and LED 2 blinks at 5Hz.</p> <p><i>Please note! The SMART CONFIG status of the WiFi module has a maximum time of 120 seconds. During this interval, the connection to the new WiFi network must be established. If this interval elapses without a new connection, the WiFi module will reconnect to the previously configured network or, if the latter is no longer available, it will return to low power status.</i></p>
TAB 5: Restoring the WIFI module to SMART CONFIG state	

Before proceeding, check again that the smartphone is connected to the desired network and that LED2 on the control unit is blinking at a fast frequency (5Hz, SMART CONFIG WiFi module); If LED2 is not blinking at a fast frequency, then it is not possible to connect the control unit to the WiFi network. In this case, repeat the initialization sequence described in Table 5. Launch the "Smart Life" APP. On the main screen of the App, tap the "+" icon and then "Add device". The search begins. When the device is detected, confirm the WiFi network settings. At the end of the adding procedure, press "Done". The main screen of the App will look as follows:

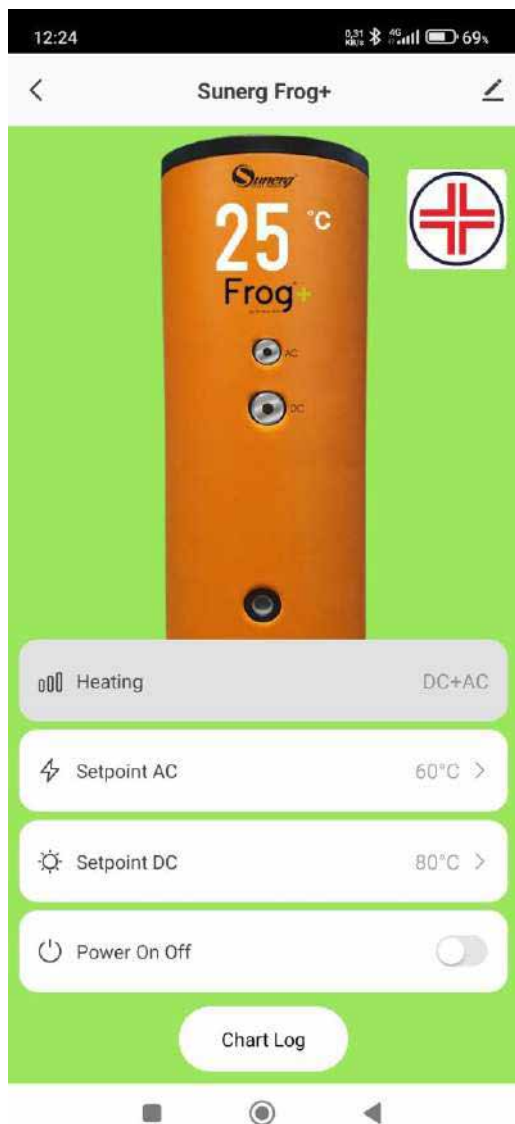

Img. 2: Example of APP screen appearance

Img. 2 shows the appearance of the App. In the main screen on the left, there is the disinfection symbol that appears only during the anti-legionella treatment. The image on the right illustrates how the graphical representation of the boiler temperature recording appears. To navigate between the two screens, the buttons at the bottom are used.

Command insertion

With the control unit in the ON state, press and briefly release the central button. The command prompt appears on the display with the indication [C _]. Use the upper and lower buttons to adjust a value in the 'Command' column of the table below. Once the number corresponding to the desired command is selected, to confirm, press and briefly release the central button.

Command	Action																
C_	Command prompt. No command selected																
C0	Set up the WiFi module in SMART CONFIG mode. See the Pairing section Smartphone Device .																
C1																	
C2	<p>Displays the status of the WiFi module represented in numerical form. The representation is of the type [U x] where x is replaced by a numerical digit from the following list:</p> <table> <tbody> <tr> <td>SMART_CONFIG_STATE</td> <td>[U 0]</td> </tr> <tr> <td>AP_STATE</td> <td>[U 2]</td> </tr> <tr> <td>WIFI_NOT_CONNECTED</td> <td>[U 2]</td> </tr> <tr> <td>WIFI_CONNECTED</td> <td>[U 3]</td> </tr> <tr> <td>WIFI_CONN_CLOUD</td> <td>[U 4]</td> </tr> <tr> <td>WIFI_LOW_POWER</td> <td>[U 5]</td> </tr> <tr> <td>SMART_AND_AP_STATE</td> <td>[U 6]</td> </tr> <tr> <td>WIFI_STATE_UNKNOW</td> <td>[U 7]</td> </tr> </tbody> </table>	SMART_CONFIG_STATE	[U 0]	AP_STATE	[U 2]	WIFI_NOT_CONNECTED	[U 2]	WIFI_CONNECTED	[U 3]	WIFI_CONN_CLOUD	[U 4]	WIFI_LOW_POWER	[U 5]	SMART_AND_AP_STATE	[U 6]	WIFI_STATE_UNKNOW	[U 7]
SMART_CONFIG_STATE	[U 0]																
AP_STATE	[U 2]																
WIFI_NOT_CONNECTED	[U 2]																
WIFI_CONNECTED	[U 3]																
WIFI_CONN_CLOUD	[U 4]																
WIFI_LOW_POWER	[U 5]																
SMART_AND_AP_STATE	[U 6]																
WIFI_STATE_UNKNOW	[U 7]																
C3	A scrolling message is displayed in the format x.y.z, where numeric values appear in place of the fields x, y, and z. The message represents the firmware version of the MCU. For example, it may show '1.0.0'. The message scrolls three times, then the display returns to showing the temperature of the probe. Communicate this information if technical assistance is requested.																
C4	Enable/Disable anti-legionella: Upon confirming the command, [On] is displayed on the screen if it is enabled, [OFF] if it is disabled.																

Tab6: command list

Antilegionella

The antilegionella function can only be enabled/disabled from the control panel interface. The command to use is [C 4] (see § "Enter a command"); Upon confirmation of the command, the display responds with:[On] if antilegionella is enabled;[OFF] if antilegionella is disabled;The chosen setting is non-volatile.When the antilegionella function is enabled, the first disinfection intervention occurs 1 minute after enabling.

When the antilegionella function is enabled, a disinfection is done after one hour upon each restart of the control panel from the 230Vac power supply.During the disinfection treatment, the boiler setpoint is fixed at 65°C and both heaters (AC+DC) are used.

The thermostatic function follows the following logic: boiler temperature > 66°C heaters OFF boiler temperature < 64°C heaters ON; The treatment lasts a constant 60 minutes. During the treatment, the points at the bottom of the displays of the control unit blink alternately and the disinfection symbol appears on the main screen of the app. After this interval, the control unit periodically repeats the treatment with a period of one week. The execution of the anti-legionella function can only be interrupted from the control interface of the control unit, disabling the function with command C4. The specified times are subject to a indicative accuracy of +-10%. The factory default setting is anti-legionella enabled.



Sunerg Solar Energy Srl
Via Donini, 51
Loc. Cinquemiglia
06012 Città di Castello - PG
info@sunergsolar.com
www.sunergsolar.com
+39 075 85 40 018
P.IVA 03728000542